

Specification Sheet

Domestic #10-16 Special High Hex Washer Head Drill Screws

Material: 1022 Carbon Steel **### (Melted in USA) ###**

Point Style: #3 Point Self Drill

Drilling Capacity: .036-.175"

Finish: Zinc (p/n AA250) / TanCor Coated (1000 Hr. Salt Spray)

Origin: Manufactured in Rockford, Illinois in ISO 9001: 2015 Plant

Head mark: Lower case "b"

Specifications: Made to SAE J 78, IFI-113 & ASTM C 1513

Sealing Washers: 9/16" OD bonded washers can be assembled to these parts

Installation Caution: Impact tools are not recommended! During installation, they may exert excessive torque causing the screws to break in some thicker applications.

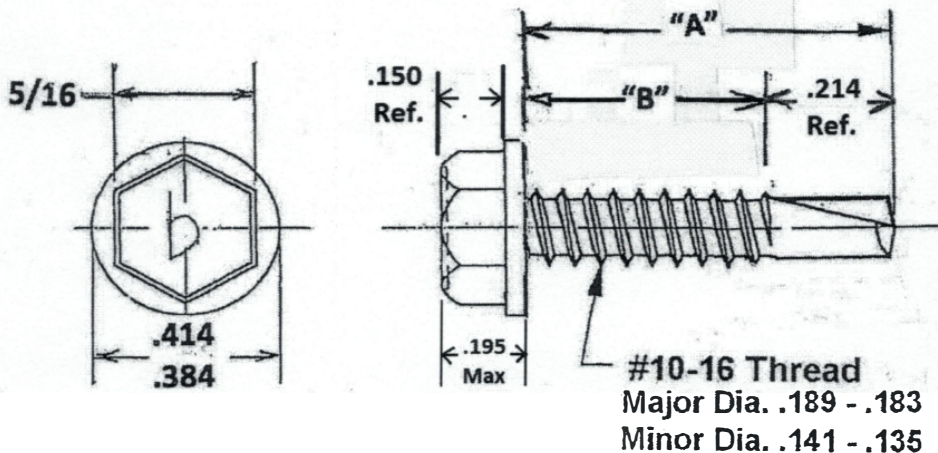

Cat#	Screw Length	Thread Length	
		A*	B*
AA250 (251)	3/4"	.520	.770
AA270	1"	.770	1.270
AA295	1-1/2"	1.270	

*Manufacturing tolerances apply

Fastener Values (Minimum)

Tensile	Shear	Torque
2100 Lbs.	1400 Lbs.	61 In. Lbs.

Pull-Out Values in Lbs.

20 Ga.	18 Ga.	16 Ga.	14 Ga.	12 Ga.	.125"
291	493	698	959	1467	2059

Above values were obtained during laboratory testing and should only be used as a guide. Appropriate safety factors should be applied.